

Reconstructing embedding spaces of coupled dynamical systems from multivariate data

S. Boccaletti^{§,†}, D.L. Valladares^{†,*}, Louis M. Pecora[‡], Hite P. Geffert[‡] and T. Carroll[‡]

[§] *Istituto Nazionale di Ottica Applicata, Largo E. Fermi, 6, 150125 Florence, Italy*

[†] *Departamento de Física y Matemática Aplicada, Universidad de Navarra, Pamplona, Spain*

^{*} *Departamento de Física, Univ. Nac. de San Luis, Argentina and*

[‡] *Code 6343, Naval Research Laboratory, Washington, D.C., 20375*

(Dated: October 4, 2001)

A method for reconstructing dimensions of subspaces for weakly coupled dynamical systems is offered. The tool is able to extrapolate the subspace dimensions from the zero coupling limit, where the division of dimensions as per the algorithm is exact. Implementation of the proposed technique to multivariate data demonstrates its effectiveness in disentangling subspace dimensionalities also in the case of emergent synchronized motions, for both numerical and experimental systems.

PACS: 05.45.Tp, 05.45.Xt, 45.10.-b

The characterization of chaotic and irregular measured time series with the help of nonlinear analysis tools is a subject of great scientific interest [1]. A preliminary fundamental task in all analysis techniques is how to reconstruct correctly the strange chaotic attractors from observed scalar data. To this purpose, it has been shown that an embedding can be obtained from time delayed coordinates of the observed variables [2], by means of which one can reconstruct the chaotic attractor of a given dynamics, and then use it for characterization [3], prediction [4], measurement, modeling or control [5] purposes. Alternative procedures have been proposed based on the reconstruction of the main features of the chaotic dynamics by means of the interspike interval technique [6], or by adaptive methods [7]. The embedding technique of Ref. [2] depends on the suitable choice of two parameters, namely the embedding time and the embedding dimensions. While the former may be easily obtained as the first minimum of the mutual information function [8], a correct determination of the system dimensionality is an essential problem to be solved in order to approach correctly any following steps of a nonlinear data analysis.

A popular method that is used for measuring the minimal embedding dimension is the so called *false nearest neighbor* (FNN) method, originally introduced by Kennel *et al.* [9], and later improved and reelaborated in order to face specific analysis tasks [10]. The method consists in marking as *false nearest neighbors* at dimension m those pairs of nearest neighbors m -dimensional embedded vectors whose distance at dimension $m + 1$ exceeds a given number of times their distance at dimension m , thus accounting for possible self-intersections of the flow due to insufficient dimensionality in the embedded space. A vanishing fraction of FNN marks the minimum dimensionality needed to properly reconstruct the chaotic flow. This technique has been later improved [10], also complementing this analysis with the one on the signal surrogates [11].

In this Letter, we discuss how to extend the dimension reconstruction problem to the case of multivariate

data analysis, that is to the case in which an observer is presented with a system composed by n weakly coupled non identical dynamical subsystems (of dimensions l_1, l_2, \dots, l_n , respectively), and extracts separately scalar quantities $x_i(t)$ out of each subsystem i ($i = 1, \dots, n$). If the observer is interested in probing global properties of the system under study (and if the subsystem variables are all to all coupled), then the usual reconstruction methods work regardless on the particular variable $x_i(t)$ on which embedding is performed. However, this gives information on the full phase space dimensionality. There are relevant cases, such as detection of synchronization processes [12, 13], or detection of interdependence of dynamics [14], for which the determination of the dimensionality of each subsystem is needed. Synchronization features have been largely studied for both coupled chaotic [12, 13] and space time chaotic [15] systems, as well as analyzed and studied in experiments and natural phenomena [16]. Recently, various attempts of providing a unifying formalism encompassing the major synchronization features have been done [17], whose applications to real data rely on a proper determination of the subspace dimensions onto which the global dynamics should be projected to look for functional relationships.

The problem can be stated as follows. Consider having n weakly coupled non identical dynamical systems, and suppose that an observer is able to measure separately scalar quantities $x_i(t)$ out of each subsystem i ($i = 1, \dots, n$). In order to properly reconstruct the dimensions l_1, l_2, \dots, l_n , let's consider the vector

$$\bar{z} \equiv [x_1(t), x_1(t - \tau_1), x_1(t - 2\tau_1), \dots, x_1(t - (m_1 - 1)\tau_1), x_2(t), x_2(t - \tau_2), \dots, x_2(t - (m_2 - 1)\tau_2), \dots, x_n(t), x_n(t - \tau_n), \dots, x_n(t - (m_n - 1)\tau_n)], \quad (1)$$

where τ_i ($i = 1, \dots, n$) are n different embedding times. $\bar{z} \in R^m$ ($m = \sum_{i=1, n} m_i$) is a vector whose first (second, third, ..., n^{th}) m_1 (m_2, m_3, \dots, m_n) components result from the embedding of the x_1 (x_2, x_3, \dots, x_n) scalar

variable with embedding time τ_1 ($\tau_2, \tau_3, \dots, \tau_n$). The embedding times τ_i can be different from each other, since different observed variables $x_i(t)$ may show different mutual information properties [8].

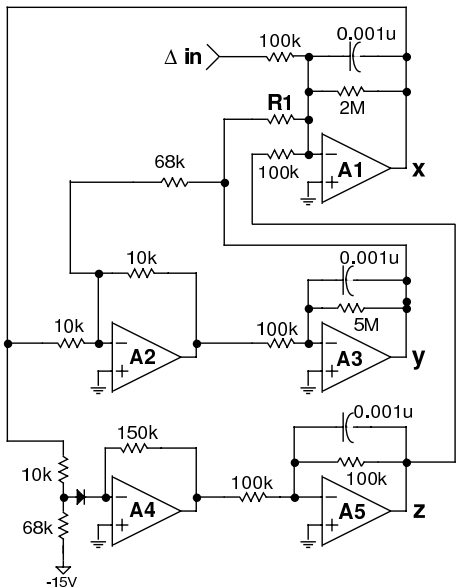

FIG. 1: The experimental setup. Rössler-like circuit used to generate data. For the first (the second) circuit, the resistor $R1$ was $221\text{ k}\Omega$ ($R1 = 178\text{ k}\Omega$).

Suppose now we start at dimension m realized with a choice of an initial set of subspace dimensions $\{m_i\}$ (usually one begins with $m_i = 1$, $i = 1, \dots, n$), and to consider all m -dimensional vectors \bar{z}_j , $j = 1, \dots, N$, N being the total number of available measurements. We associate to each vector \bar{z}_j its nearest neighbor $\bar{z}_{NN,j}$ at dimension m . Furthermore, we introduce n counters $\mathcal{N}_i(m)$ ($i = 1, \dots, n$), and a given threshold σ .

For each pair of nearest neighbors $\bar{z}_j, \bar{z}_{NN,j}$ we calculate the distance $d(\bar{z}_j, \bar{z}_{NN,j}, m) = \sqrt{\sum_{l=1, \dots, m} (\bar{z}_{j,l} - \bar{z}_{NN,j,l})^2}$. We then pass from dimension m to dimension $m + 1$.

This latter operation can be performed in n different ways. Precisely from $m \equiv (m_1, \dots, m_i, \dots, m_n)$ we can pass to any space $m + 1 \equiv (m_1, \dots, m_i + 1, \dots, m_n)$ ($i = 1, \dots, n$). In those spaces, we calculate the new distances $d_i(\bar{z}_j, \bar{z}_{NN,j}, m + 1)$. The condition $d_i(\bar{z}_j, \bar{z}_{NN,j}, m + 1) \geq \sigma d(\bar{z}_j, \bar{z}_{NN,j}, m)$ is taken as a signature of the falseness of nearest neighbors with respect to increasing by one the dimension of the i^{th} subspace. Consequently, the counter $\mathcal{N}_i(m)$ is increased by one.

After having probed all pairs of nearest neighbors at dimension m , the set of counters $\mathcal{N}_i(m)$ ($i = 1, \dots, n$) retains information on how many nearest neighbors are false with respect to increasing by one the dimension of

Coupling value	$m(x_1)$	$m(x_2)$	m_1, m_2
$\varepsilon=0.02$	6	6	3,3
$\varepsilon=0.05$	6	6	3,3
$\varepsilon=0.13$	6~7	6~7	~3,3
$\varepsilon=0.16$	6	6	3,2
$\varepsilon=0.50$	6	6	3,2

TABLE I: Detection of subspace dimensionality for system (2). First column indicates the coupling value, second (third) column reports the calculation of false nearest neighbor dimension m [9] over the signal x_1 (x_2). Fourth column indicates the dimensions of subspaces m_1 and m_2 as calculated by the proposed method. The considered coupling values determine the following dynamical states: $\varepsilon = 0.02$ unsynchronized evolution, $\varepsilon = 0.05$ phase synchronization, $\varepsilon = 0.13$ intermittent lag synchronization, $\varepsilon = 0.16$ lag synchronization (LS), $\varepsilon = 0.50$ almost complete synchronization (ACS) [13]. Notice that, for both LS and ACS, the subspaces dimensionality reconstruction is affected by the emergence of the corresponding synchronization manifolds, due to large couplings between the two subsystems.

the corresponding i^{th} subspace. For any $\mathcal{N}_i(m)$ above a preassigned threshold δ we increase by one the dimension of the corresponding subspace, and we perform the whole process again at dimension $m + p$, p being the number of $\mathcal{N}_i(m)$ counters that overcome δ . The process is stopped when all $\mathcal{N}_i(m)$ are below δ at once, thus gathering simultaneous information on both the dimension of the full reconstructed phase space, and the dimensions m_i of each subsystem. We emphasize that this procedure should work well for weak coupling and in fact be exact for zero coupling, thus we think of it as an extension of the zero coupling case.

The above algorithm makes use of the two thresholds σ and δ . σ discriminates the falseness of a pair of nearest neighbors, and therefore must exceed the unity. On the other hand, a too large σ value would lead to the consequence that the condition $d_i(\bar{z}_j, \bar{z}_{NN,j}, m + 1) \geq \sigma d(\bar{z}_j, \bar{z}_{NN,j}, m)$ is never satisfied. The criteria for a proper choice of σ are largely discussed in Refs. [1, 9]. In what follows we always take $\sigma = 10$, that in our case represents a good compromise between the two discussed extrema. Furthermore, we have checked that the dimension estimate was insensitive to σ within some reasonable range around that value.

As for δ , it indicates the percentage of FNN at which the reconstruction process is stopped. In fact, for ideal data, one should put $\delta = 0$ and wait for a vanishing fraction of FNN. However, in all practical cases, data are corrupted by noise, or by a finite measurement resolution.

A direct consequence of the above said is that the FNN counters $\mathcal{N}_i(m)$ saturates to a non zero value, thus one has to estimate a minimal acceptable fraction of FNN to stop the dimension reconstruction process, by estimating the level of noise corrupting the available data.

In order to demonstrate the effectiveness of the proposed method, we provide here below three applications for $n = 2$. The first application is the reconstruction of the subspaces for a system described by

$$\begin{aligned}\dot{x}_{1,2} &= -\omega_{1,2}y_{1,2} - z_{1,2} + \varepsilon(x_{2,1} - x_{1,2}), \\ \dot{y}_{1,2} &= \omega_{1,2}x_{1,2} + 0.15y_{1,2}, \\ \dot{z}_{1,2} &= 0.2 + z_{1,2}(x_{1,2} - 10),\end{aligned}\quad (2)$$

where $\omega_{1,2} = 0.97 \pm 0.02$. System (2) is constituted by two coupled non identical chaotic Rössler system [18].

Coupling value	$m(x_1)$	$m(x_2)$	m_1, m_2
$\varepsilon=0.008$	7	7	3,4
$\varepsilon=0.012$	7	7	3,4

TABLE II: Same as in Table I, but for system (3). First column indicates the coupling value, second (third) column reports the calculation of false nearest neighbor dimension m [9] over the signal x_1 (x_2). Fourth column indicates the dimensions of subspaces m_1 and m_2 as calculated by the proposed method. The considered coupling values determine the following dynamical states: $\varepsilon = 0.008$ unsynchronized evolution, $\varepsilon = 0.0012$ phase synchronization [13].

By increasing the coupling strength ε , several different kind of synchronized motions emerge. In particular, Ref. [13] identified phase, intermittent lag, lag and eventually almost complete synchronization (a situation where the differences $|x_1(t) - x_2(t)|$, $|y_1(t) - y_2(t)|$, $|z_1(t) - z_2(t)|$ are all bounded in time by a quantity much smaller than the attractor diameter). By numerically integrating system (2), we take the scalar signals $x_{1,2}(t)$ as two distinct measurements for the reconstruction task.

The second application deals with structurally non equivalent subsystems described by

$$\begin{aligned}\dot{x}_1 &= -\omega y_1 - z_1 + \varepsilon(x_2 - x_1), \\ \dot{y}_1 &= \omega x_1 + 0.15y_1, \\ \dot{z}_1 &= 0.2 + z_1(x_1 - 10), \\ \dot{x}_2 &= w_2 + 0.25x_2 + z_2 + \varepsilon(x_1 - x_2), \\ \dot{y}_2 &= 3 + y_2w_2, \\ \dot{z}_2 &= -0.5y_2 + 0.05z_2, \\ \dot{w}_2 &= -x_2 - y_2.\end{aligned}\quad (3)$$

For $\omega = 0.925$, system (3) is constituted by a chaotic Rössler oscillator [18] coupled with a hyperchaotic Rössler oscillator [19]. As a function of ε , Refs. [13] discriminates between non synchronized and phase synchronized dynamics. As above, we take for reconstruction the scalar signals $x_{1,2}(t)$ as they come from numerical integration of system (2) with initial conditions $x_1 = 0.1, y_1 = 0.2, z_1 = 0.3, x_2 = y_2 = 0, z_2 = 15, w_2 = -20$.

The third application uses scalar signal $x_{1,2}(t)$ as measured over an experiment, whose setup is depicted in Fig. 1. The two circuits that were built were similar to the Rössler system, but they each contained only 1 piecewise linear element [20]. One of these circuits, which were similar but not identical, is shown in Fig. 1. For the first (the second) circuit, the resistor $R1$ was $221\text{ k}\Omega$ ($178\text{ k}\Omega$).

A coupling circuit took the difference between x signals from the two circuits and multiplied this difference by a coupling constant c . The resulting signal, Δ , was fed back in to each circuit at the place indicated, so that the two circuits looked like a pair of similar Rössler oscillators coupled by the difference of x variables.

Coupling strength (* 10^{-4})	$m(x_1)$	$m(x_2)$	m_1, m_2
5	6	6	3,3
5.5	7	6	3,3
6.25	7	6	3,3
7.14	7	6	3,3
8.33	7	6	2,4

TABLE III: Detection of subspace dimensionality for the experimental output of the system described in Fig. 1. First column indicates the coupling value. Second (third) column reports the calculation of false nearest neighbor dimension m [9] over the signal x_1 (x_2). Fourth column indicates the dimensions of subspaces m_1 and m_2 as calculated by the proposed method. As the coupling strength increases, the systems experience a smooth transition from no synchronized evolution to generalized synchronization.

The x signals from the two circuits were digitized at a rate of 20,000 samples per second, which was about 20 points per cycle of the Rössler oscillation. Time series of length 100,000 to 500,000 points were acquired.

In all cases we have taken τ_1 (τ_2) from the first minima of the mutual information function calculated on x_1 (x_2) [8]. Calculations of nearest neighbors dimensions have begun with $m_1 = m_2 = 1$. In table I (II,III) it is reported the process of detection of subspace dimensionality for the system (2) (the system (3), the experimental

outputs of the system described in Fig. 1). The first column indicates the coupling value at which variables $x_{1,2}$ were measured. The second and third column report the dimensionality of the full phase space, as calculated via the application of the usual false nearest neighbor technique [9] over the signal x_1 (x_2). Finally, in the fifth column, we show the results of the application of the above described techniques for the calculation of the subspace dimensions m_1 and m_2 . For the experimental data (table III) m , m_1 and m_2 have been taken as the dimension at which the fraction of false nearest neighbors was smaller than 0.5 % the total number of data points, since this was a satisfactory estimation of the level of noise corrupting the data.

At weak coupling values, the proposed reconstructing method is successful in disentangling the dimensions of the coupled subspaces, thus giving either information of the dimension of the reconstructed full attractor, and on the dimension of the two coupled subspaces onto which the dynamics should be projected to inspect for synchronization or other collective phenomena. For larger coupling strengths (fourth and fifth row of Table I and fifth row of Table III), the detection of subspaces dimensionality is affected by the emerging synchronization manifolds.

In conclusion, we have introduced a multivariate data analysis tool that is able to extrapolate the dimensions of weakly coupled subspaces from the zero coupling limit, where the division of dimensions as per the algorithm is exact. Implementation of the proposed technique demonstrates its effectiveness in disentangling subspace dimensionalities also in the case of emergent synchronized motions.

The Authors acknowledge F.T. Arecchi, J. Kurths, H.L. Mancini, A. Pelaez for many fruitful discussions. Work partly supported by the European Contract N^o. HPRN-CT-2000-00158.

-
- [1] see H.D.I. Abarbanel, *Analysis of Observed Chaotic Data* (Springer-Verlag, New York, 1996), H. Kantz and T. Schreiber, *Nonlinear Time Series Analysis* (Cambridge University Press, Cambridge, UK, 1997) and References therein.
- [2] F. Takens, *Detecting Strange Attractors in Turbulence*, edited by D. A. Rand and L. S. Young, *Lecture Notes in Mathematics* Vol. 898 (Springer-Verlag, New York, 1981); T. Sauer, M. Casdagli, and J.A. Yorke, *J. Stat. Phys.* **65**, 579 (1991).
- [3] P. Grassberger and I. Procaccia, *Phys. Rev. Lett.* **50**, 346 (1983); R. Wayland, D. Bromley, D. Pickett, and A. Passamente, *Phys. Rev. Lett.* **70**, 580 (1993); Dov Sherman, Ilan Be'ery *Phys. Rev. Lett.* **80**, 540 (1998).
- [4] A. K. Alparslan, M. Sayar, A. R. Atilgan *Phys. Rev. E* **58**, 2640 (1998); Christian G. Schroer, Tim Sauer, Edward Ott and James A. Yorke, *Phys. Rev. Lett.* **80**, 1410 (1998). Gong Xiaofeng, C. H. Lai *Phys. Rev. E* **60**, 5463 (1999).
- [5] see S. Boccaletti, C. Grebogi, Y.C. Lai, H. Mancini and D. Maza, *Phys. Rep.* **329**, 103 (2000) and References therein.
- [6] T. Sauer, *Phys. Rev. Lett.* **72**, 3811 (1994).
- [7] F.T. Arecchi, G. Basti, S. Boccaletti and A.L. Perrone, *Europhys. Lett.* **26**, 327 (1994); S. Boccaletti, A. Giacquinta and F.T. Arecchi, *Phys. Rev. E* **55** 5393 (1997).
- [8] A.M. Fraser and H.L. Swinney, *Phys. Rev. A* **33**, 1134 (1986); T. Buzug and G. Pfister, *Physica D* **58**, 127 (1992).
- [9] M.B. Kennel, R. Brown, and H.D.I. Abarbanel, *Phys. Rev. A* **45**, 3403 (1992).
- [10] L. Cao, A. Mees, K. Judd, and G. Froyland, *Int. J. Bifurcation Chaos* **8**, 1491 (1998); T. Aittokallio, M. Gyllenberg, J. Hietarinta, T. Kuusela, and T. Multamki, *Phys. Rev. E* **60**, 416 (1999); Rainer Hegger, Holger Kantz *Phys. Rev. E* **60**, 4970 (1999); David M. Walker, Nicholas B. Tufillaro *Phys. Rev. E* **60**, 4008 (1999).
- [11] J. Theiler, S. Eubank, A. Longtin, B. Galdrikian, and J.D. Farmer, *Physica D* **58**, 77 (1992); T. Schreiber and A. Schmitz, *Phys. Rev. Lett.* **77**, 635 (1996).
- [12] H. Fujisaka and T. Yamada, *Prog. Theor. Phys.* **69**, 32 (1983); L.M. Pecora and T.L. Carroll, *Phys. Rev. Lett.* **64**, 821 (1990); N.F. Rulkov, M.M. Sushchik, L.S. Tsimring and H.D.I. Abarbanel, *Phys. Rev. E* **51**, 980 (1995); L. Kocarev and U. Parlitz, *Phys. Rev. Lett.* **76**, 1816, (1996); S. Boccaletti and D.L. Valladares, *Phys. Rev. E* **62**, 7497 (2000).
- [13] M.G. Rosenblum, A.S. Pikovsky and J. Kurths, *Phys. Rev. Lett.* **76**, 1804 (1996); M.G. Rosenblum, A.S. Pikovsky and J. Kurths, *Phys. Rev. Lett.* **78**, 4193 (1997).
- [14] S.J. Schiff, P. So, Taeun-Chang, R.E. Burke and T. Sauer, *Phys. Rev. E* **54**, 6708 (1996).
- [15] D.H. Zanette, *Phys. Rev. E* **55**, 5315 (1997); P. Parmananda, *Phys. Rev. E* **56**, 1595 (1997); A. Amengual, E. Hernández-García, R. Montagne and M. San Miguel, *Phys. Rev. Lett.* **78**, 4379 (1997); S. Boccaletti, J. Bragard, F.T. Arecchi and H.L. Mancini, *Phys. Rev. Lett.* **83**, 536 (1999); H. Chaté, A. Pikovsky and O. Rudzick, *Physica D* **131**, 17 (1999); S. Boccaletti, D.L. Valladares, J. Kurths, D. Maza and H. Mancini, *Phys. Rev. E* **61**, 3712 (2000).
- [16] C. Schafer, M.G. Rosemblum, J. Kurths and H.H. Abel, *Nature* **392**, 239 (1998); P. Tass, M.G. Rosemblum, M.G. Weule, J. Kurths, A. Pikovsky, J. Volkmann, A. Schnitzler and H.J. Freund, *Phys. Rev. Lett.* **81**, 3291 (1998); G.D. Van Wiggeren and R. Roy, *Science* **279**, 1198 (1998); A. Neiman, X. Pei, D. Russell, W. Wojtenek, L. Wilkens, F. Moss, H.A. Braun, M.T. Huber and K. Voigt, *Phys. Rev. Lett.* **82**, 660 (1999); G. M. Hall, S. Bahar and D.J. Gauthier, *Phys. Rev. Lett.* **82**, 2995 (1999); A. R. Yehia, D. Jeandupeux, F. Alonso and M.R. Guevara, *Chaos* **9**, 916 (1999); C.M. Ticos, E. Rosa Jr., W.B. Pardo, J.A. Walkenstein and M. Monti, *Phys. Rev. Lett.* **85**, 2929 (2000).
- [17] R. Brown and L. Kocarev, *Chaos* **10**, 344 (2000); S. Boccaletti, Louis M. Pecora, A. Pelaez *Phys. Rev. E* **63**, 066219 (2001).
- [18] O.E. Rössler, *Phys. Lett.* **A57**, 397 (1976).
- [19] O.E. Rössler, *Phys. Lett.* **A71**, 155 (1979).
- [20] T. L. Carroll, *American Journal of Physics* **63**, 377

